

MOBILE REFUELLING STATION

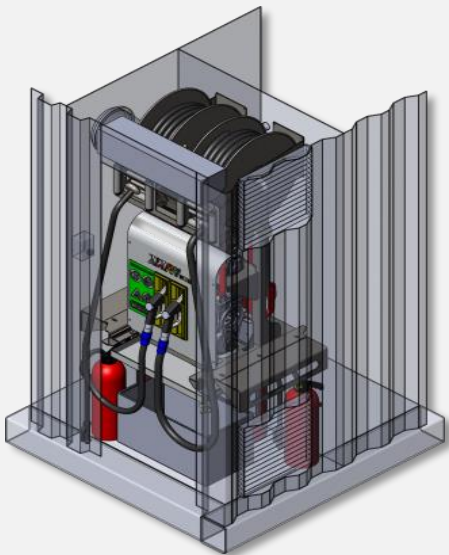

STRENGTHS



- Standard container 20" or 40"
- System ready to operate in few minutes
- Really tough container frame
- Modular concept depending on your needs
- Equipment protected by sandblasting, metallizing, and painting



MOBILE REFUELLING STATION

EQUIPMENT

FUELLING PERFORMANCES	High flow refuelling nozzle 80L/min through the 10m long 1"1/2 hose EN1361-C HD type Regular flow refuelling nozzle through the 10m long 1"1/2 hose EN1361-C HD type Flow adaptable depending on your needs
COMPLIANCE	ADR DEVP0827876A : Manufactured tank storage of flammable liquids DEVP0827677A : Installation de remplissage ou de distribution de liquides inflammables
POWER	By diesel generator or connection to an electrical network By diesel pump
TANK	Double skin, single compartment, with a capacity from 12.000 L (20') to 25.000 L (40')
PUMP	Electrical pump
INLET LINE	Hose 1"1/4
FILTRATION	In option
SAMPLING SYSTEM	Yes
MESURING SYSTEM	Two meters (one for each line) with adapted lighting for night refuelling operations
HOSE REEL	2 Hose reel Driven electrically
ELEVATING PLATFORM	N/A
REGULATION	N/A
FUNCTIONS CONTROL	All electric lines numbered on both ends and through weather tight harnesses
DIMENSIONS (L X W X H)	Standard container 20' : 6058 mm x 2438 mm x 2591 mm Standard container 40' : 12192 mm x 2438 mm x 2591 mm
ANTICORROSIVE	Container protected by sandblasting, metallizing, and painting
SAFETY	Interlock system in fail-safe configuration 5 x 9Kg dry powder fire extinguisher

INFORMATION

Contact us at : welcome@titan-defense.com
Or via our website : www.titan-defense.com

